

Inclined reinforcement to prevent soil liquefaction

K.J. McManus

University of Canterbury., Christchurch, N.Z.

J.P. Turner

University of Wyoming, Laramie, Wyoming, U.S.A.

G. Charton

University of Canterbury, Christchurch, N.Z.



2005 NZSEE
Conference

ABSTRACT: The use of inclined micropiles as reinforcement to prevent soil liquefaction in level ground has been investigated experimentally. Deposits of loose ($D_r = 0.2$ to 0.4), dry sand were prepared inside a large (2.0 m deep by 1.8 m long by 0.8 m wide) laminated box and subjected to shaking of different intensities on a one-dimensional shake table. For low intensity shaking (PGA up to 0.28 g) the cyclic shear strains were modest (up to 0.11 percent) and there was a modest settlement (0.31 percent). For higher intensity shaking, (PGA up to 0.40 g) there was a significant transformation in response with much greater cyclic shear strain (0.65 percent) and settlement (3.1 percent).

Other deposits were reinforced by use of Titan 26-14 self-drilling micropiles installed at 30 degrees inclination. Reinforcement by one inclined micropile was found to have little effect on response to shaking but installation of two diagonally opposed, inclined micropiles was found to reduce cyclic shear strain by half and settlement to one fifth that of similar un-reinforced deposits.

1 INTRODUCTION

Soil liquefaction is a significant hazard in earthquake prone regions. The recognized extent of the hazard is growing rapidly in size as regional studies continue to identify large areas of liquefiable soils. There is a growing problem of knowing how to treat sites where small, low cost structures including dwellings are planned. Large projects can more easily absorb the costs of traditional ground improvement techniques such as deep dynamic compaction, stone columns, and vibro-compaction and large structures can economically be founded on piles. But these techniques are seldom found to be economical for smaller projects and they are not applicable to retrofitting numerous existing affected structures.

Traditional ground improvement techniques are highly invasive, require large-size equipment, generate considerable amounts of noise and vibration, make a big mess, and need a large site to operate in. They are unsuited to small or congested sites or where there are near neighbours. By contrast micropiles can be installed with lightweight equipment, quietly, and in confined spaces, even inside of existing buildings.

Horizontal micropiles (usually called “soil nails”) have become widely accepted as a means of reinforcing slopes against sliding failures both from static gravity induced forces and earthquakes. This study has investigated the possibility of adapting micropiles to stabilize level ground during earthquakes by installing them as diagonal reinforcement.

Traditional installation techniques for micropiles and soil nails involve drilling, insertion of steel reinforcing, followed by grouting, and are not suited for loose granular soil below the water table (the most typical case for soils susceptible to liquefaction) without the use of temporary casing. However, self-drilling micropiles (e.g. Ischebeck Titan micropiles) are now available which are ideally suited to installation in loose, liquefiable sands without use of temporary casing.

There is growing understanding that cyclic shear strains rather than cyclic shear stresses determine the onset of soil liquefaction. Soil liquefaction is a result of the tendency of loose sands to densify with shaking, the resulting effort of the soil to expel the excess pore water causing a temporary increase in pore water pressure and loss of effective confining stress. A number of researchers (Silver and Seed, 1971, Youd, 1972) have shown experimentally that the densification of dry sands is controlled by cyclic shear strains and not shear stresses. Further, the existence of a threshold cyclic shear strain has been found below which soil densification does not occur.

Therefore, if the cyclic shear strain in the soil can be kept below this threshold value, then pore pressure should not be generated and liquefaction should not occur. Dobry and Ladd (1980) have found that for different sands, prepared by different methods, and tested at different effective confining pressures the threshold cyclic shear strain for significant pore pressure generation is approximately 0.1 percent.

Dobry et. al. (1982) have proposed a method for estimating the cyclic shear strain amplitude at a point in the ground as:

$$\gamma_{cyc} = 0.65 \frac{a_{max}}{g} \frac{\sigma_v r_d}{G(\gamma_{cyc})} \quad (1)$$

in which a_{max} = estimated peak ground acceleration at the site and r_d = an empirical reduction factor. The soil shear modulus G is highly non-linear and is a function of the cyclic shear strain. G_{max} , the small strain modulus may be found for the soil profile by use of seismic CPT profiling, for instance. Modulus reduction curves as a function of cyclic shear strain are available (e.g. Vucetic and Dobry, 1991).

From Equation (1), if the shear modulus, G , for the soil mass is enhanced sufficiently by diagonal reinforcement, and the cyclic shear strain maintained below the threshold value of 0.1 percent, then there should be minimal generation of pore water pressure and no liquefaction. Further, by reducing cyclic shear strain the reinforcement should also act to maintain the soil's own initial stiffness which otherwise tends to degrade rapidly.

This study has examined experimentally the effectiveness of inclined micropiles as reinforcement to reduce soil cyclic shear strains during shaking. Full-size prototype micropiles (Titan 26-14) were installed in loose sand in a large (2 m deep x 1.8 m long x 0.8 m wide) laminated shear box then subjected to different levels of shaking. Results were compared to similar soil deposits without micropile reinforcement.

2 LAMINATED SAND TANK

Prototype inclined micropiles were tested in a large laminar sand tank on a one degree of freedom shaking table at the University of Canterbury. The purpose of the laminar tank was to simulate free-field shaking response by allowing the soil to deform in simple shear with minimal boundary effects from the tank (e.g. Hushmand et. al. 1988, Iai 1991, Whitman et. al. 1981). The tank design used for this study follows from that of Hushmand et al., and is shown in Figure 1. The tank has internal dimensions of 1.8 m long by 0.8 m wide by 2.0 m deep.

The laminates were made from 100 mm by 50 mm cold-formed steel channel that was laid on its flat and welded into rectangular frames. Teflon strips of 150 mm long by 10 mm wide by 1 mm thick were glued to both sides of the laminates at six locations to minimize friction. Tests showed that the strips produced a coefficient of friction of 0.07, indicating that at normal stresses equivalent to those at the base of the tank, the load required to shear the laminates was only 2 percent of the load required to shear the soil mass.

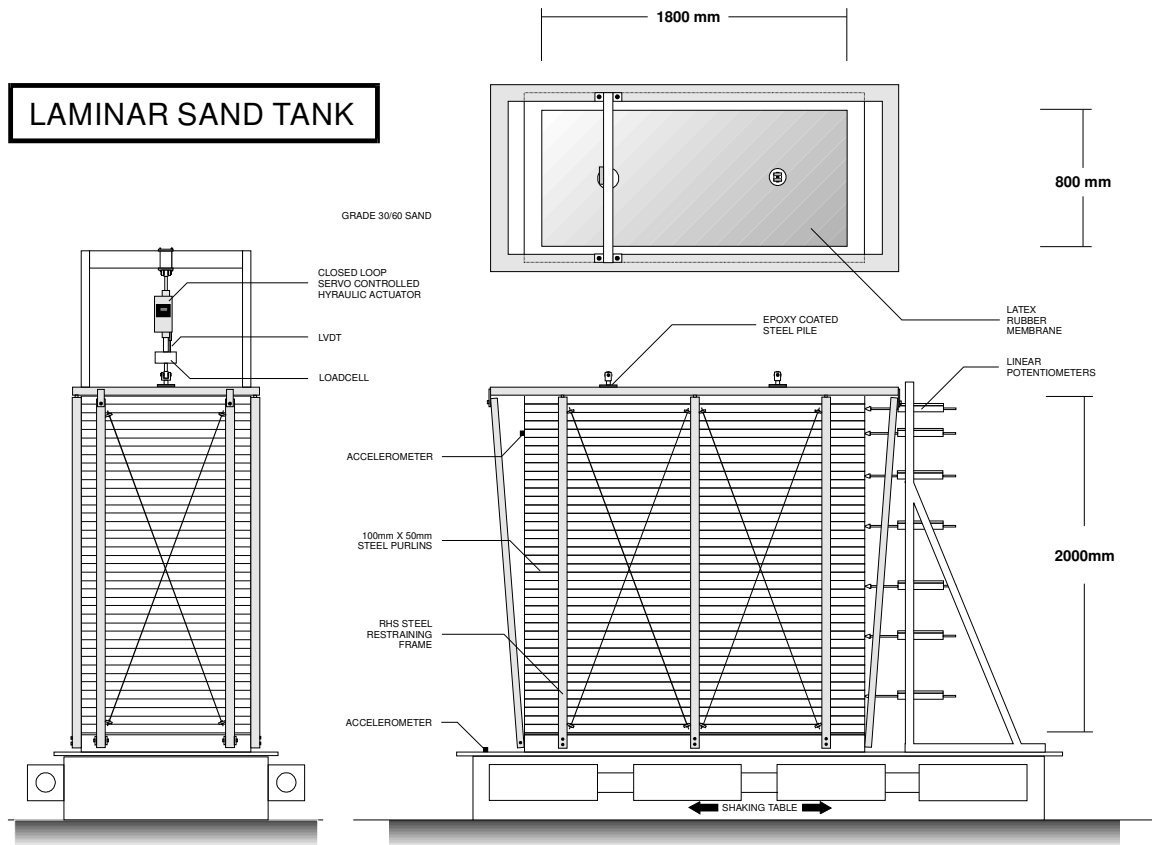

Figure 1. Laminar sand tank

Soil was contained within the tank by a flexible membrane liner. Latex rubber sheets, each 1 mm thick, were draped over the inside of the laminates and glued to the top laminate.

The laminates were supported by a steel frame that was constructed from 50 mm by 50 mm rectangular hollow section (RHS), with 10 mm diameter rods acting as cross-bracing members. The frame restricted the laminates to move only in the direction of the shaking table and also supported the stack of laminates when the tank was empty. Both the top-cap and the side members of the supporting frame were coated with Teflon strips to reduce friction during shaking.

3 INSTRUMENTATION

Five potentiometers (Showa type 50LP300) were placed in contact with tank laminates at various heights above the tank base (1.07 m, 1.34 m, 1.55 m, and 1.97 m) and fixed rigidly to the shaking table in order to measure relative lateral displacements of the tank laminates during shaking.

An accelerometer (Kyowa AS-5GA) was fixed to one of the tank laminates near to the soil surface (1.77 m above tank base) in order to measure soil acceleration and a similar accelerometer was fixed directly to the shaking table.

Settlement of the soil surface was measured by fixing a vertically oriented potentiometer to the tank support frame and making contact with an aluminium plate resting on the sand surface.

4 SOIL DEPOSITS

The soil used was an industrial grade 30/60 silica sand supplied by Commercial Minerals Ltd, Auckland, New Zealand, with properties given in Table 1. This soil was selected because it is suitable for air pluviation and can be re-used without degradation.

Table 1. Soil Properties

Property	Symbol	Value
Density of Solid Particles	ρ_s	2.65 t/m ³
10% finer	D ₁₀	0.30 mm
60% finer	D ₆₀	0.45 mm
minimum voids ratio	e_{min}	0.53
maximum voids ratio	e_{max}	0.83
Steady State Friction Angle	ϕ_{ss}	33°

Soil deposits were prepared by air pluviation. Sand flowed from a hopper through a gate, was collected in a suspended funnel, then flowed down a 95 mm diameter flexible hose, discharging through a wire mesh diffuser into the laminated tank. The diffuser was made from a 100 mm diameter by 300 mm long section of plastic tube that was packed with wire mesh. By discharging sand from the diffuser directly onto the surface of the deposit, a low initial relative density (six deposits, $Dr = 0.17 - 0.26$) was achieved. The sand densified somewhat during each episode of shaking enabling some tests to be performed in higher densities (as high as $Dr = 0.4$).

Two cone penetrometer tests (CPT) were performed in one of the deposits after deposition and prior to shaking. The penetration was found to be consistent throughout the deposit with cone resistance q_c ranging from 1 MPa to 1.4 MPa.

5 SHAKING TABLE

The characteristics of the University of Canterbury shaking table are given in Table 2. The table is driven by a closed-loop, servo-controlled hydraulic actuator with an MTS Teststar 2 system controller. Each test was performed under displacement control, with the cyclic table displacements generated by entering the required amplitude, frequency, and number of cycles into the controller.

Table 2. Characteristics of the University of Canterbury Shaking Table

Property	Value
Plan Dimensions	4.0 m x 2.0 m
Maximum Allowable Load	200 kN
Maximum Horizontal Force	200 kN
Maximum acceleration with a mass of 5 tonne	2.7 g
Maximum Velocity	1.0 m/s
Maximum Displacement	0.30 m

6 SOIL RESPONSE TO SHAKING

Four deposits were constructed without micropile reinforcement and subjected to shaking to verify behaviour of the laminar tank and to determine baseline soil response. Soil deposits were subjected to individual "earthquakes" consisting of 26 cycles of 1 Hz sine wave shaking at three amplitudes: +/- 20 mm, +/- 30 mm, and +/- 40 mm.

Shake table acceleration response was somewhat "jerky", as shown for a typical +/- 40 mm test in Figure 2. The ideal, "smooth" response of the table would have been perfect sine waves of +/- 0.16 g, instead the response was unsymmetrical and overlain by high frequency noise with average peak

values of approximately 0.26 g. This “jerky” response is arguably more representative of real earthquakes than a pure sine wave would have been.

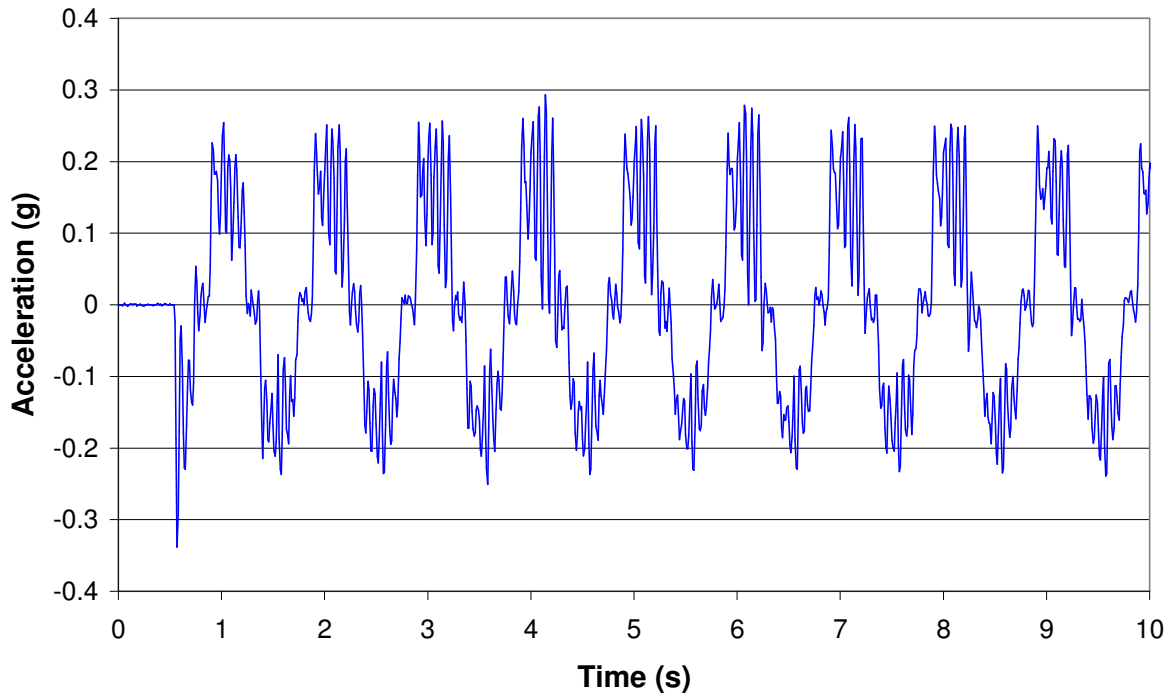

Figure 2. Acceleration Response of Shake Table for +/- 40 mm, 1 Hz shaking.

Laboratory experiments using sine wave excitation of soils are considered to be more severe than real earthquakes where there are usually relatively few excursions near to the peak ground acceleration (PGA). Seed (1970) argued that peak ground accelerations used for sine wave based laboratory experiments should be scaled up by a factor of 1/0.65 when making predictions of soil response for real earthquakes. The levels of shaking used for this study are summarised in Table 3 together with equivalent PGA values as recommended by Seed (1970).

Table 3. Levels of Shaking and Equivalent Peak Ground Accelerations

Programmed Displacement (26 cycles, 1 Hz)	Average Peak Cyclic Acceleration (g)	Equivalent PGA (g)
+/- 20 mm	0.15	0.23
+/-30 mm	0.18	0.28
+/-40mm	0.26	0.40

During shaking, the displacement measurements showed that the soil mass deformed in a linear, simple shear mode from the tank base to a height of 1.6 m, then deformed in a non-linear, irregular mode from 1.6 m to the surface at 2.0 m. The deformation of the surface soil seems to have been affected by surface waves of complex shape that were observed during shaking. Typical displacement measurements are shown in Figure 3.

The cyclic shear strain during shaking is shown in Figure 4 for the three amplitudes of shaking. The peak displacement of each transducer for each cycle of shaking was captured and divided by the height above the tank base then averaged over all of the transducers to give an average peak shear strain for each cycle. Peak strain decreased during each "earthquake" as the initially loose soil densified. For the lower amplitude shaking (0.23 g and 0.28 g) the cyclic shear strains were modest (0.23 percent and 0.11 percent for cycle 13) but for the higher amplitude shaking (0.40 g) the cyclic shear strain was much greater (0.65 percent for cycle 13).

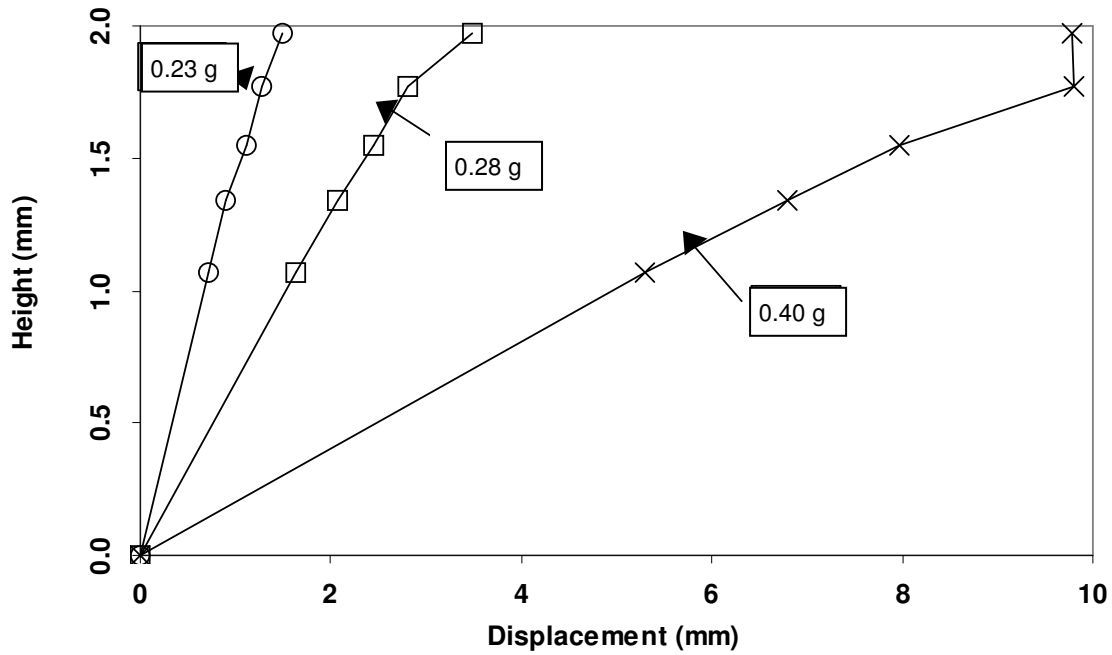

Figure 3. Displacement profiles for unreinforced soil deposits.

Significant settlements occurred at the surface of each soil deposit during shaking as the initially loose sand densified. The amount of settlement varied significantly depending on the amplitude of shaking, as shown in Figure 5. For the shaking at 0.23 g and 0.28 g the settlement was modest and similar (0.31 percent and 0.35 percent), but, for the higher level shaking at 0.40 g the settlement was much greater (3.1 percent).

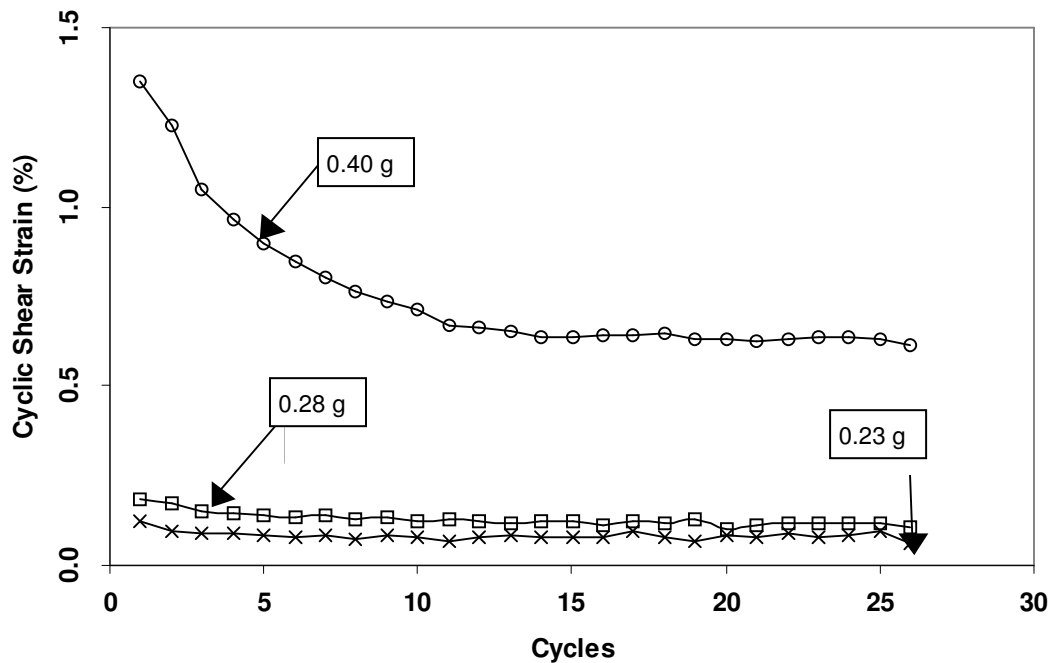

Figure 4. Average peak cyclic shear strain for unreinforced soil deposits (Initial $D_r = 0.2$)

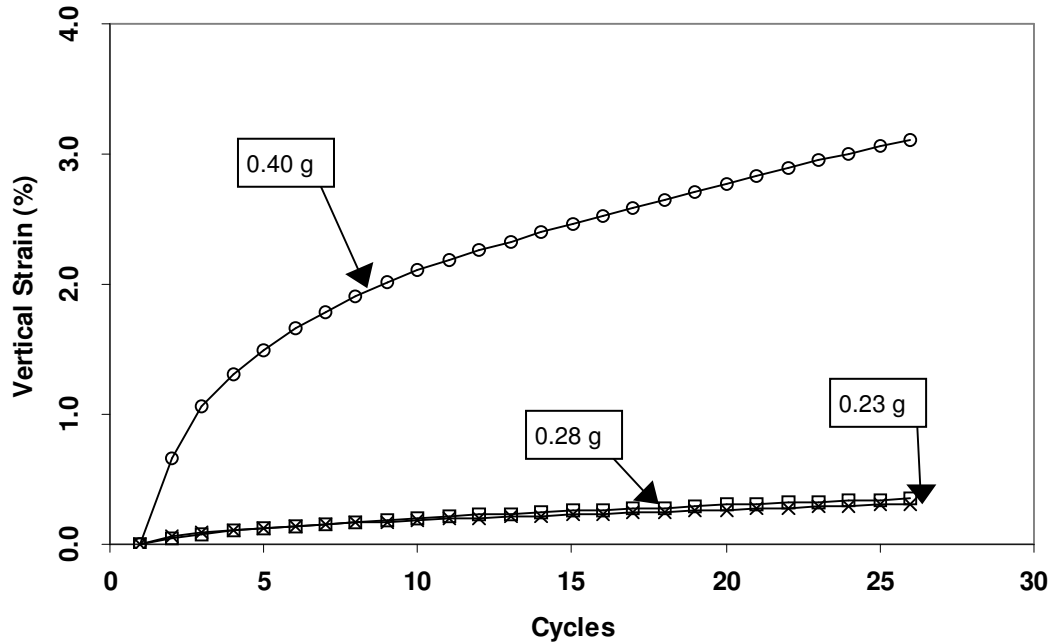

Figure 5. Settlement of unreinforced soil deposits (Initial $D_r = 0.2$).

Clearly, a significant transformation in response occurred between the shaking at 0.28 g and the shaking at 0.40 g, with settlement jumping from 0.35 percent to 3.1 percent. The shaking at 0.28 g caused a cyclic shear strain of 0.11 percent which is very close to the threshold value for liquefaction of 0.1 percent suggested by Dobry and Ladd (1980). Increasing the shaking intensity further to 0.40 g may have triggered a “collapse” of the soil fabric with a large reduction in shear stiffness and increase in settlement. This “collapse” may be equivalent to liquefaction occurring in a saturated sand deposit.

7 MICROPILE INSTALLATION

Two soil deposits were reinforced with diagonal micropiles. One deposit was reinforced with a single micropile and was reinforced with two diagonally opposed micropiles, as shown in Figure 6. Titan 26-14 self-drilling micropiles supplied by Ischebeck (NZ) Ltd were used as reinforcement. Titan micropiles consist of high-strength hollow steel threaded bars installed by a self-drilling process with a sacrificial drill bit. Grout is injected during drilling at low pressure to mix with the surrounding soil and provide bonding and corrosion protection.

For this study, the micropiles were installed into loose sand at shallow (2 m) depth and so the bars were installed simply by pushing with hydraulic rams (a cone penetrometer pushing rig), as shown in Figure 7. An oversize cone-shaped drill head was fixed to the pile tip to create an annular space that was progressively filled with grout during pushing. A photograph of the completed installation with two diagonally opposed micropiles is shown in Figure 8.

The grout mix used was 50:50 by weight of ordinary Portland cement : water, with 3 percent bentonite by weight of cement added to stabilize the grout and reduce water loss to the dry sand. The unconfined compressive strength of the cured grout was 9 MPa at 7 days and 11 MPa at 28 days.

The micropiles were exhumed from the soil after each test and were found to be highly uniform in cross-section with a diameter of 100 mm +/- 15 mm.

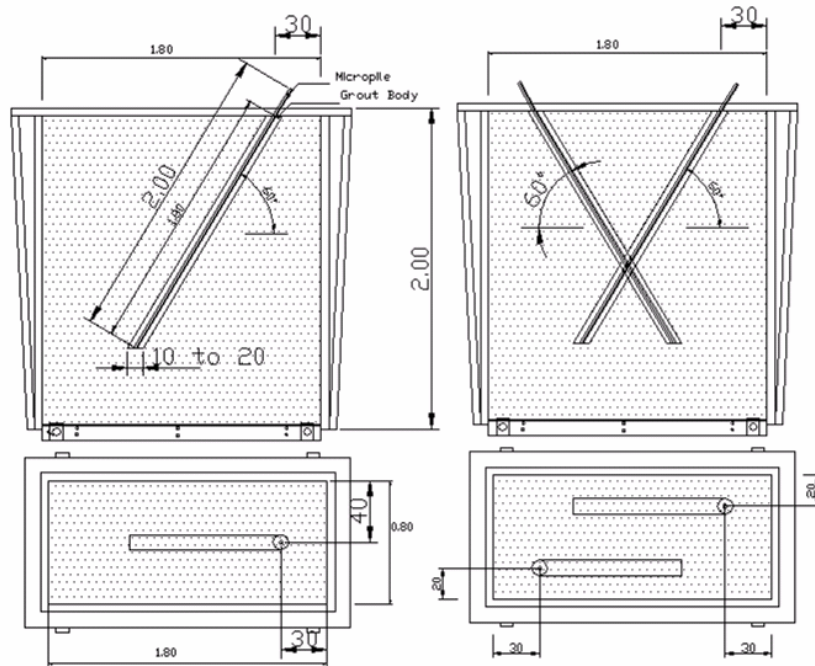

Figure 6. Layout of micropile reinforcement in laminar tank.



Figure 7. Installation of inclined micropiles.



Figure 8. Completed installation of two inclined micropiles.

8 RESPONSE OF REINFORCED SOIL DEPOSITS

The two reinforced soil deposits (one micropile and two micropiles) were subjected to the same levels of shaking as unreinforced deposits of similar density (Initial $D_r = 0.4$). The response of the reinforced deposits is compared to equivalent unreinforced deposits in Figures 9 and 10, showing average peak cyclic shear strain and settlement during shaking.

The response of the soil deposit with one inclined micropile was quite similar to the unreinforced deposit. The average peak cyclic shear strains were similarly high (0.54 percent for the unreinforced deposit and 0.64 percent for the reinforced deposit after 13 cycles) and the total settlements were also quite similar (1.2 percent and 1.1 percent). The main notable difference in response was that the deposit with one micropile initially had a larger response in terms of both cyclic shear strain and settlement than the unreinforced deposit, with the response steadily declining during the test.

The response of the soil deposit with two diagonally opposed micropiles was reduced to about half of the cyclic shear strain of the unreinforced deposit (0.24 percent after 13 cycles) and about one fifth of the settlement (0.24 percent). This level of cyclic shear strain is somewhat above the threshold of 0.1 percent for liquefaction suggested by Dobry and Ladd (1980), but the settlement was reduced substantially suggesting that liquefaction in an equivalent saturated deposit might have been prevented.

Nevertheless, the increase in shear stiffness of the deposit provided by the reinforcement was low considering the steel cross-section introduced. From the measured cyclic shear strains shown in Figure 9, the equivalent shear modulus, G , at mid-depth of the deposit (1 m) may be calculated as 380 KN/m^2 for the unreinforced deposit and 1010 KN/m^2 for the deposit with two micropiles. The equivalent shear modulus provided by the steel reinforcement, if the steel cross-section were fully mobilised, is $52,000 \text{ KN/m}^2$. Obviously, the capacity of the micropiles is hardly mobilised suggesting that reinforcement of much lower strength and stiffness may provide similar benefit at lower cost.

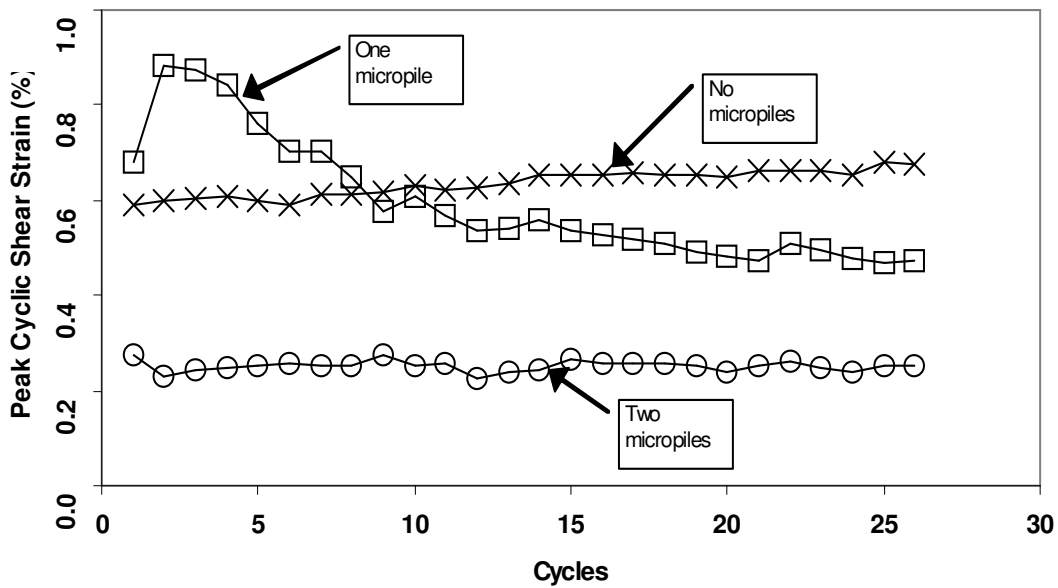

Figure 9. Average peak cyclic shear strain: PGA = 0.40 g, initial Dr = 0.4.

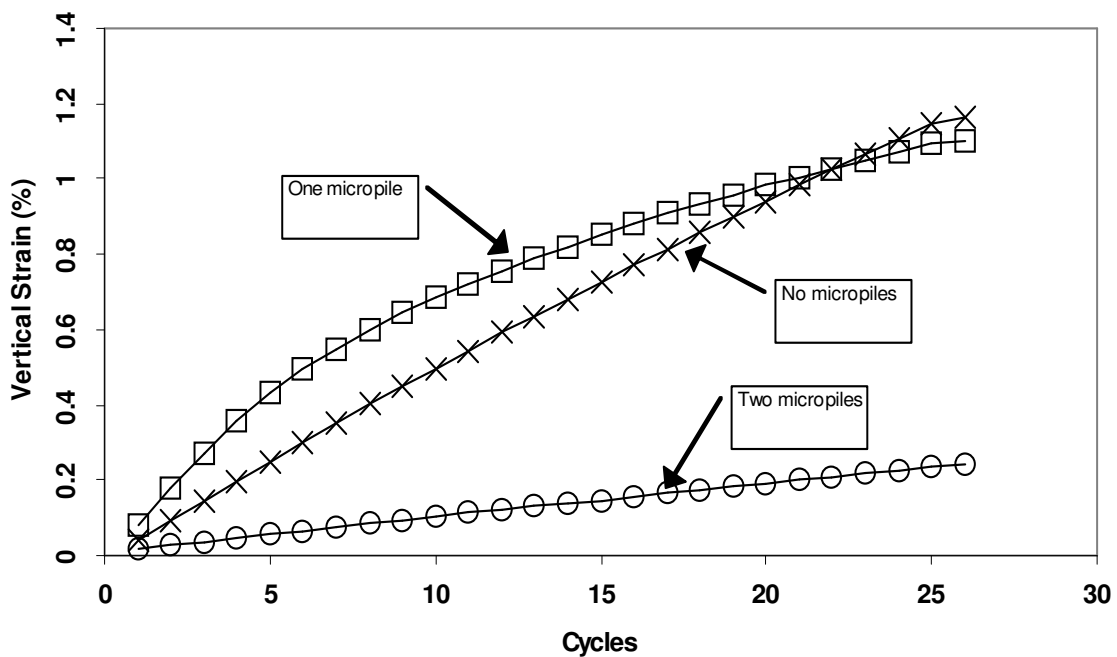

Figure 10. Settlement during shaking: PGA = 0.40 g, initial Dr = 0.4

9 CONCLUSIONS

The large-size laminar tank performed well on the shaking table with linear simple shear being generated in deposits of loose sand in all but the upper 0.2 m. Shaking of loose, unreinforced sand deposits with accelerations of 0.23 g and 0.28 g caused peak cyclic shear strains of up to 0.11 percent and minimal settlements of up to 0.35 percent. Shaking at higher level (0.40 g) caused a transformation in response with large cyclic shear strains (0.65 percent) and large settlements (3.1 percent).

Installation of Titan self-drilling micropiles at inclinations of 30 degrees was achieved readily by direct-push with simultaneous grout injection at low pressure.

Reinforcement of sand deposits with a single inclined micropile had little effect on response to shaking. Reinforcement with two, diagonally opposed micropiles had a significant effect, reducing cyclic shear strain by half and settlement to one fifth that of a similar unreinforced deposit. It is probable that the two micropiles would have prevented liquefaction of the soil deposit in this case (initial $D_r = 0.4$, $PGA = 0.40 g$) if it had been saturated with water.

The efficiency of the reinforcement was low, with relatively little of the potential increase in stiffness from the steel cross-section utilised.

Future research should investigate use of much lighter reinforcement elements which may provide similar benefits at greater economy.

10 ACKNOWLEDGEMENTS

This project received funding from the New Zealand Earthquake Commission Research Foundation under grant EQC 01/477. Ischebeck(NZ) Ltd. provided the micropiles and John Yonge provided much advice on installation. Alistair Chambers designed and developed the laminar tank. John Maley assisted with construction and setup of the apparatus and operated the shake table. Richard Pascoe operated the CPT rig and installed the micropiles. Neil Charters contributed to the analysis.

REFERENCES:

- Dobry, R. and Ladd, R.S. (1980). Discussion to "Soil liquefaction and cyclic mobility evaluation for level ground during earthquakes, : by H.B. Seed and "Liquefaction potential: science versus practice," by R.B. Peck, *J. of the Geotechnical Engineering Division*, ASCE, Vol. 106, No. GT6, pp. 720-724.
- Dobry, R., Ladd, R.S., Yokel, F.Y., Chung, R.M., and Powell, D. (1982). "Prediction of pore water pressure buildup and liquefaction of sands during earthquakes by cyclic strain method," *NBS Building Science Series 138*, National Bureau of Standards, Gaithersburg, Maryland, 150 pp.
- Hushmand, B., Scott R.F. & Crouse C.B. (1988). "Centrifuge liquefaction tests in a laminar box", *Geotechnique*, Vol. 38, No 2, pp. 253-262.
- Iai, S. (1991). "A Strain Space Multiple Mechanism Model For Cyclic Behavior of Sand and its Application," *Research Note No.43*, Earthquake Engineering Research Group, Port and Harbour Research Institute, Ministry of Transport, Japan. May 1991.
- Seed, H. B. and Idriss, I. M. (1970). *A simplified procedure for evaluating soil liquefaction potential*, Earthquake Engineering Research Center, University of California, Berkeley, Nov. 1970, 38 p.
- Silver, N.L. and Seed, H.B. (1971). "Volume changes in sands during cyclic loading," *J. of the Soil Mechanics and Foundations Division*, ASCE, Vol. 97, No. SM9, pp. 1171-
- Vucetic, M. and Dobry, R. (1991). "Effect of soil plasticity on cyclic response," *J. of Geotechnical Engineering*, ASCE, Vol. 117, No. 1, pp. 89-107.
- Whitman, R.V., Lambe, P.C. & Kutter, B.L. (1981). "Initial Results from a Stacked-Ring Apparatus for Simulation of a Soil Profile". *Proceedings, International Conference on Recent Advances in Geotechnical Earthquake Engineering and Soil Dynamics*, St Louis, Mo., April 26 – May 3, 1981.
- Youd, T.L. (1972). "Compaction of sands by repeated shear straining," *J. of the Soil Mechanics and Foundations Division*, ASCE, Vol. 98, No. SM7, pp. 709-725.